

lamp removal

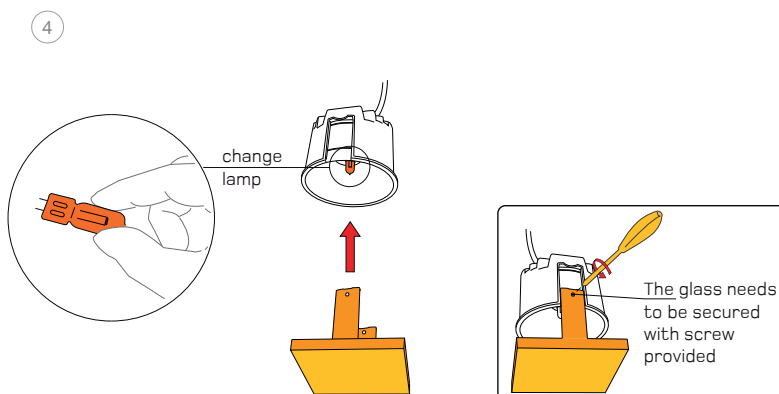
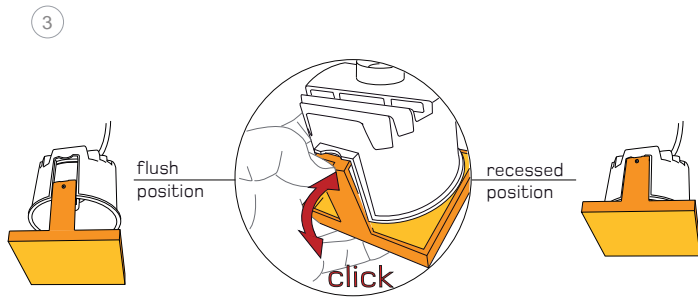
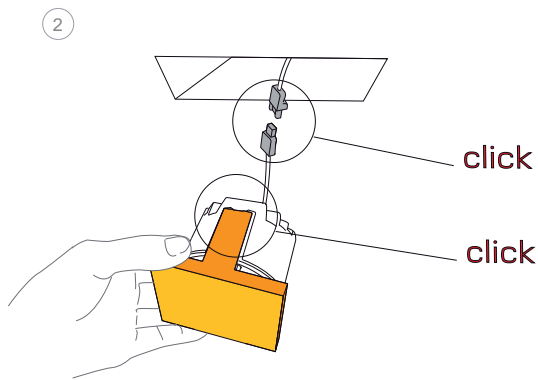
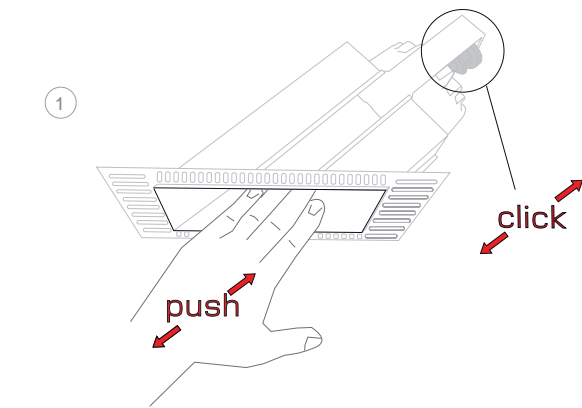

installation instructions / 150 plaster-in wallwash:

P100RWW-LVC	P100SWW-LVC
P100RWW-CDM-TC	P100SWW-CDM-TC
P100RWW-CFL	P100SWW-CFL
P100RWW-LED-XI	P100SWW-LED-XI
P100RWW-CL	P100SWW-CL

cut-out:
115mm x 170mm

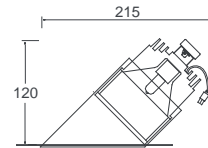

cut-out:
115mm x 170mm

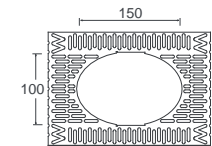
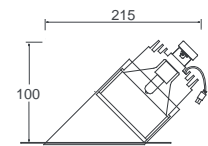
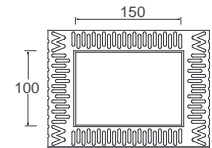

Registration number is WEE/FG0362QY

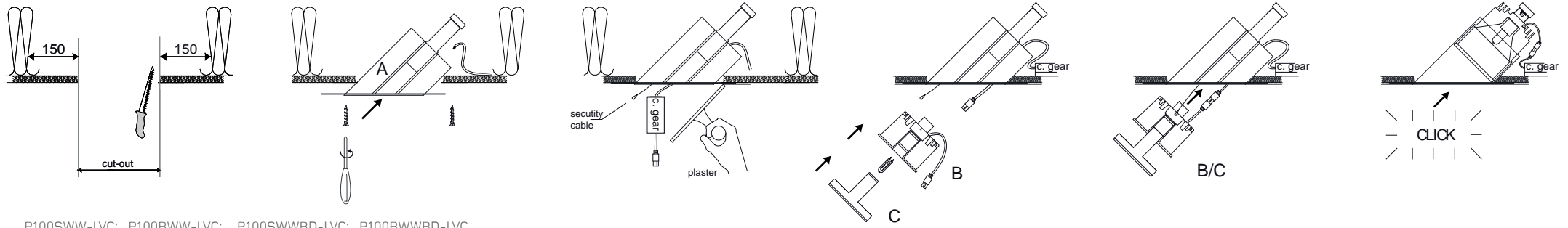

P100SWW-LVC; P100RWW-LVC; P100SWWRD-LVC; P100RWRD-LVC

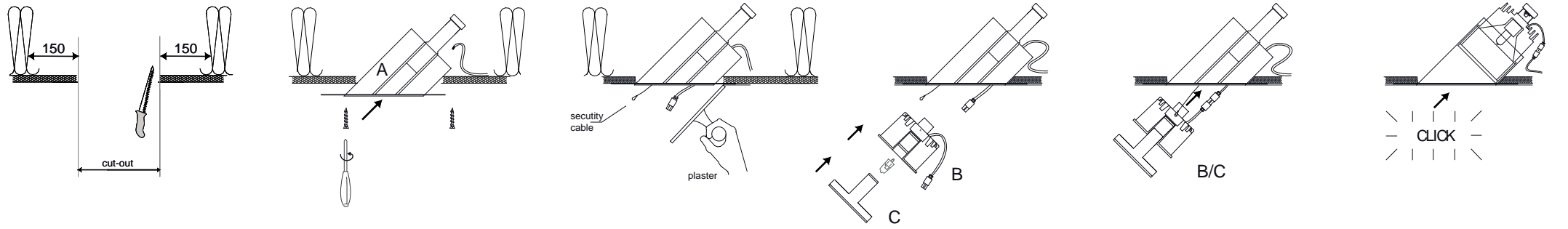

P100SWW-MVC; P100RWW-MVC; P100SWWRD-MVC; P100RWRD-MVC

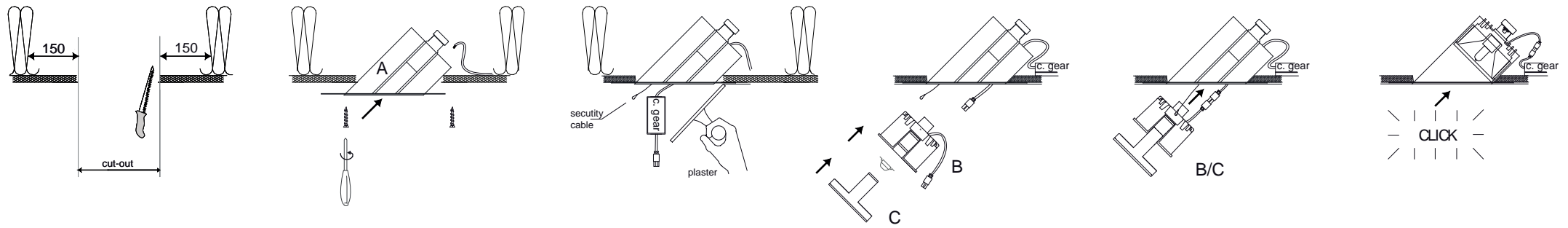

P100SWW-LED; P100RWW-LED; P100SWWRD-LED; P100RWRD-LED;

1 Ensure the housing is fixed securely in place

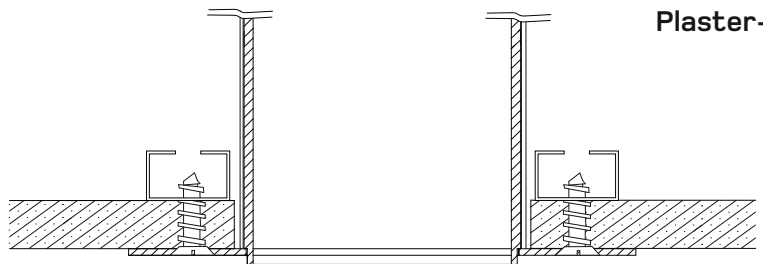

Plaster-in finish instructions

2 Distribute an even amount of plaster that conceals the trim of the housing.

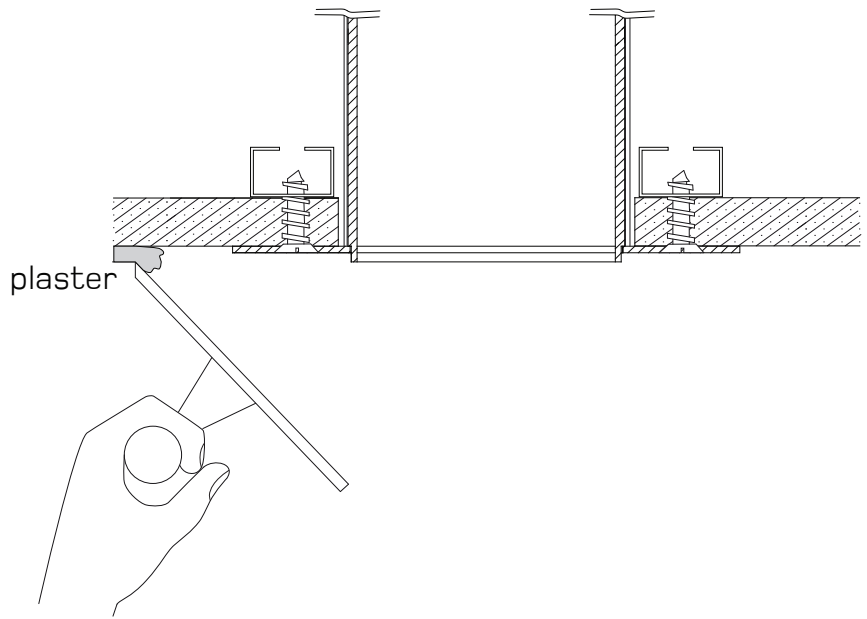

3 Ensure there is a smooth and neat finish at the edge of the housing. To achieve the correct result no plaster is to pass the housing lip

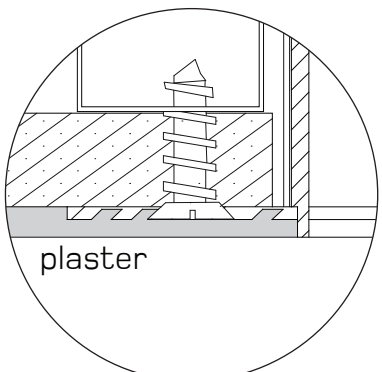
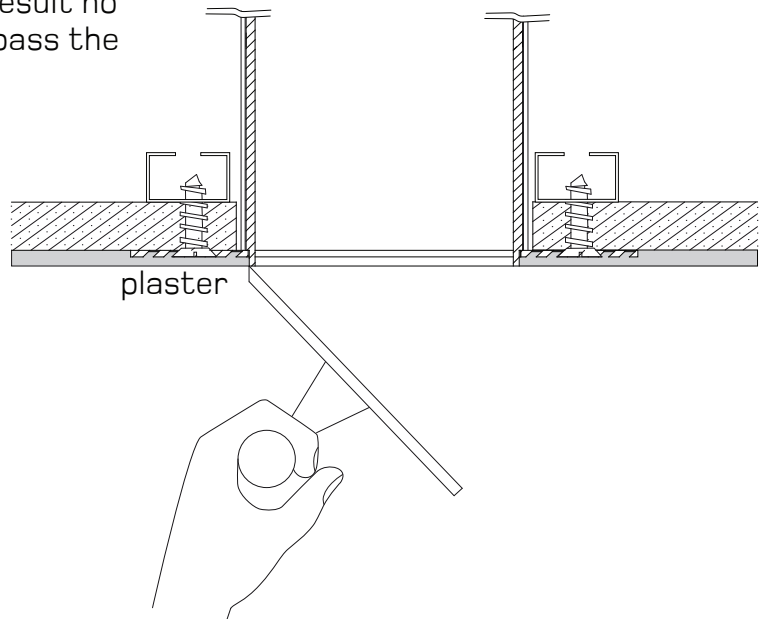

Correct finish

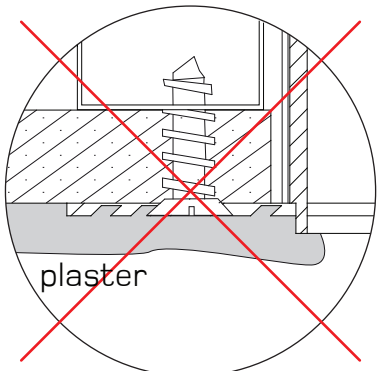

Incorrect finish

GB

Installation

Disconnect the mains supply before installation. This fixture is to be installed and maintained by a recognised electrician. Care must be taken when plastering the housing that no excess plaster is applied on the inside of the luminaire housing as this is detrimental to the operation of the luminaire.

1. Cut-out the required recessing aperture and screw fix the frame (A) to the soffit. (as shown) Use a timber batten backing to the soffit if stronger fixing points are required.
2. Remove any insulation or obstruction within 150mm of the mounting frame.
3. Plaster the ceiling using the lip of the frame as a stop bead for the plaster finish.
4. Clean any excess plaster from inside the mounting frame as this will have detrimental effect on the operation of the luminaire.

Make the electrical connection as follows:

Fitting Type: P100SWW-LVC; P100RWWLVC; P100SWWRD-LVC; P100RWWRD-LVC;

A. Remove the female 230/240v 50/60Hz 2-pin connector plug from the luminaire and wire the plug to the transformer. Refer to the transformer for a detailed wiring diagram. Use only Whitegoods supplied transformers.

B. Wire the mains input to the supplied transformer, refer to the transformer for a detailed wiring diagram.

C. Re-connect the female plug from the mains transformer to the male plug attached to the luminaire.

Fitting Type: P100SWWRD-MVC; P100RWWRD-MVC; P100SWW-MVC; P100RWW-MVC

A. Unplug the female 230/240v 50/60Hz 3-pin connector from the lamp insert and wire the mains cable into position.

B. Re-connect the female to male plug.

Fitting Type: P100SWW-LED; P100RWWLED; P100SWWRD-LED; P100RWWRD-LED; TBA.

Fitting Type: P100SWW-CDMSM; P100RWW-CDM-SM;

A. Unplug the female 230/240v 50/60Hz 2-pin plug from the lamp insert and wire the control gear secondary side to the plug. Refer to the control gear for a detailed wiring diagram. Use only Whitegoods supplied control gear.

B. Wire the mains input to the supplied transformer, refer to the transformer for a detailed wiring diagram.

C. Re-connect the female plug from the mains transformer to the male plug attached to the luminaire.

5. Insert the specific lamp into the lamp insert as shown.

6. Clip the glass stirrup (C) onto the lamp cartridge (B) (The glass stirrup can be connected in a the flush or recessed position, dependant on lamp type, see overleaf)

7. Connect the retaining cord to the luminaire insert and 'push-click' the lamp insert assembly (B/C) into the frame (A)

Re-lamping Procedure

Disconnect the mains power supply before re-lamping

1. 'Push-click' the lamp cartridge assembly (B/C) to release from the frame (A)
2. Suspend the assembly on the retention wire
3. Remove the glass stirrup (C)
4. Replace the lamp within the lamp insert(B). (dispose of lamp according to specific regulations)
5. Re-fit the glass stirrup to lamp insert (The glass stirrup can be connected in a flush or recessed position as described above)
6. 'Push-click' the lamp insert assembly (B/C) into the frame (A)

Installation

The installation of these products should only be carried out by a suitably qualified electrician in accordance with the instructions supplied with the product. All installation instructions can be downloaded from our website. We recommend that they are included with construction issue drawings and specifications.

Ceiling void depths for recessed downlights and linear luminaires: The Ceiling void depth should ideally be 25mm deeper than the overall height of the luminaire. When a fire-hood and/or a remote emergency pack is to be used, the void depth and space surrounding the luminaire will need to be increased.

Dimensions and specification

The drawings, dimensions and finishes of the products in this catalogue and any accompanying information are purely indicative. Great care is taken to provide up to date information in this publication, however, due to a continuing programme of design and development, we reserve the right to change these dimensions without prior notice. Please check the website for most up to date information. If a dimension is critical to the success of your project, please confirm it directly with the technical department. Throughout this publication, cut-out sizes refer to the aperture required when fittings are mounted in soft plasterboard. For fibrous tiles, timber, metal tiles and cast-in construction, check dimensions on site, or ask for a sample. Whitegoods reserves the right to discontinue any product in this publication at any time without prior notice.

Performance

All photometric data supplied is taken from a standard production luminaire tested under ideal laboratory conditions and may vary from data taken in alternative conditions. All calculated light levels and/or lighting plots provided are offered for guidance only. The customer must satisfy themselves that luminaires proposed are suitable for the application intended in all performance and physical criteria.

Temperature and physical environment

All products are tested with stated lamp wattage. Incorrect lamp types and wattages may effect efficiency, create glare and seriously overheat the luminaire. Adequate ventilation and free air space around fittings (in accordance with the installation instructions supplied with the product) will be necessary when used in confined spaces where elevated temperatures will occur. All luminaires are designed to operate in a maximum 30degree ambient temperature. Operating in ambient temperatures above this can affect performance and the mechanical functionality of the luminaire.

Intellectual property

In order that we can continue to develop innovative quality products, we believe it is of critical importance that we protect our ideas and visions. Therefore any infringement of our intellectual property will be vigorously pursued.

Returns

We cannot offer refunds on Custom or Tailored products, Standard product may be eligible for re-stocking within 3 months of original purchase date, subject to a 30% handling charge. All original packaging and documentation must be present and goods must be in original condition.

Service

Whitegoods will endeavor to fulfill all orders as quickly as possible and treat all customers with the highest regard. For further information about Whitegoods products and services, please visit www.whitegoods.com.

WEEE directive



The Waste Electrical and Electronic Equipment Directive (WEEE Directive) is the European Community directive 2002/96/EC on waste electrical and electronic equipment, together with the RoHS Directive 2002/95/EC which became European Law in February 2003, setting collection, recycling and recovery targets for all types of electrical goods. This imposes responsibility for the disposal of waste electrical and electronic equipment (WEEE) on the manufacturers of such equipment. To meet these targets Whitegoods has become a member of Lumicom to allow us to meet the current and future directives. For further information on the WEEE directive please contact our offices. WEEE Registration number is WEE/FG0362QY